

Parts List:

- (x1) 19in 1x1 Stock
- (x2) 5in 1x1 Stock
- (x2) 10in 1x1 Stock
- (x2) 20in Hex Shaft
- (x8) End Bearing Gussets
- (x2) Angle Gusset 90 Degrees
- (x2) Corner Gusset
- (x4) Side Bearing Gusset
- (x1) Narrow Parallel Mount Gusset
- (x2) Piston Bracket (found in "Misc" folder)
- (x1) 0.375in Radius, 17in Long Round Tube (make this)
- (x1) 15in VersaRoller (found in "Rollers and Tubing" folder)
- (x1) 15.25in VersaRoller
- (x4) VersaRoller End Mounts
- (x12) Roller Treads (make these; see below)
- (x2) 0.5in Hex 18T Pulley
- (x1) 1in Hex 18T Pulley
- (x1) 775 VersaPlanetary Single Stage 10 1
- (x8) 0.5 in Flanged Hex Bearing
- (x4) 0.5 in Hex Lock Collar
- (x2) 0.5in Hex Spacer 0.25in
- (x1) 0.5in Hex Spacer 0.5in

A Brief List of Major Steps:

1. Nahhh...you got this on your own!

Front View Drawing

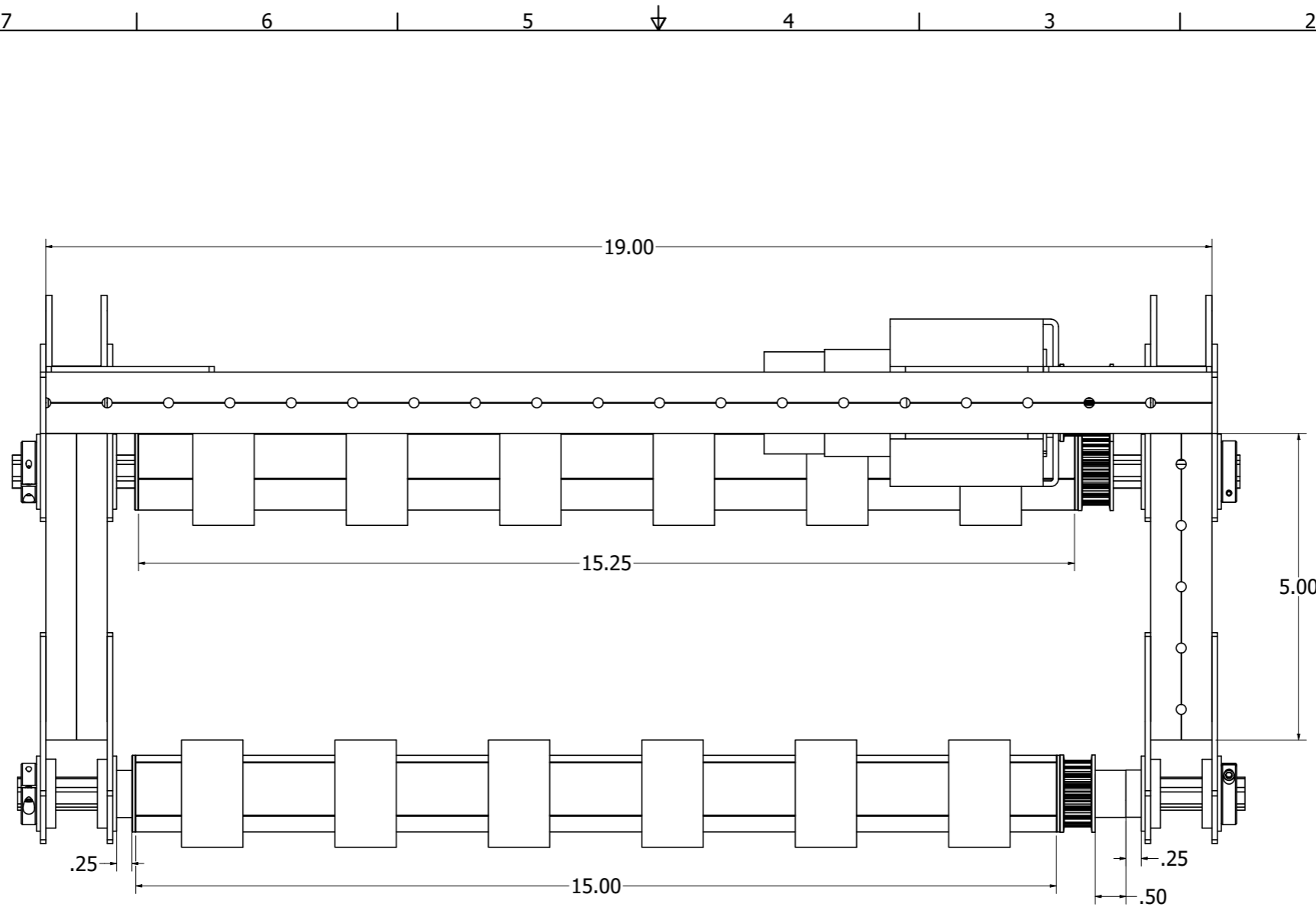

| | | | | | |
|----------|------|-----------|-------|--------|--------------|
| DRAWN | Reid | 6/24/2020 | | | |
| CHECKED | | | TITLE | | |
| QA | | | | | |
| MFG | | | | | |
| APPROVED | | | | | |
| | | | SIZE | DWG NO | REV |
| | | | D | | |
| | | | SCALE | 1 : 1 | SHEET 1 OF 1 |

Top View Drawing

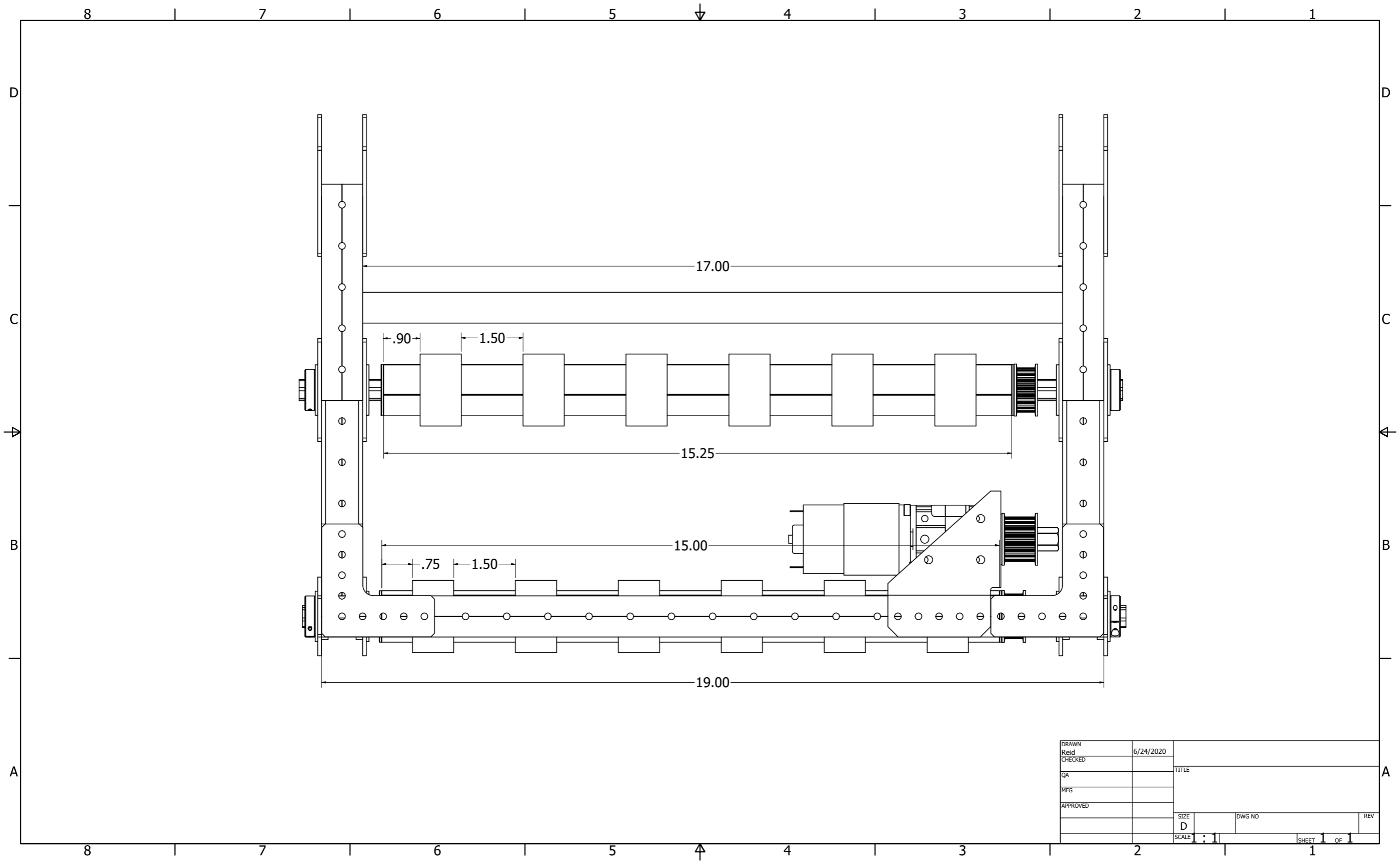

| | | | |
|---------------|-----------|-------------|--------------|
| DRAWN Reid | 6/24/2020 | | |
| CHECKED | | TITLE | |
| QA | | | |
| MFG | | | |
| APPROVED | | | |
| | | SIZE D | DWG NO |
| | | SCALE 1 : 1 | SHEET 1 OF 1 |

Side View Drawing

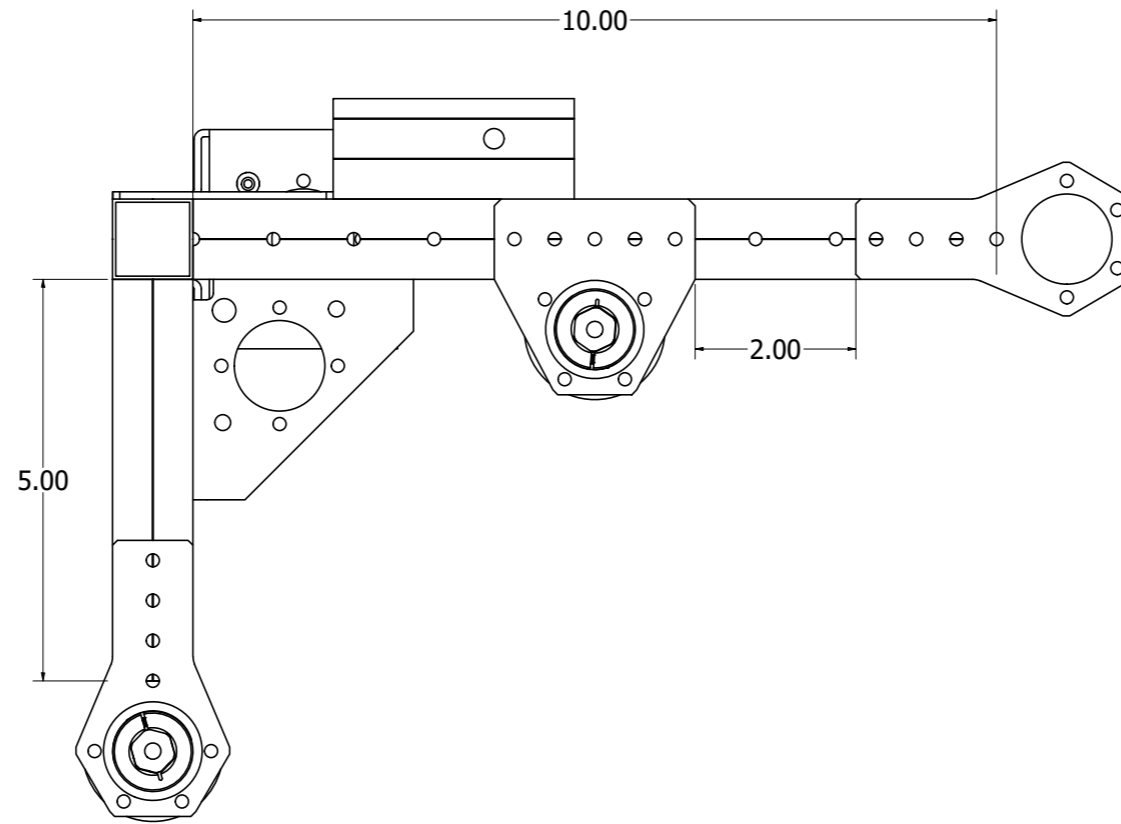

| | | | | | |
|----------|------|-----------|-------------|--------------|-----|
| DRAWN | Reid | 6/24/2020 | | | |
| CHECKED | | | TITLE | | |
| QA | | | | | |
| MFG | | | | | |
| APPROVED | | | | | |
| | | | SIZE | DWG NO | REV |
| | | | D | | |
| | | | SCALE 1 : 1 | SHEET 1 OF 1 | |

Roller Tread Drawing

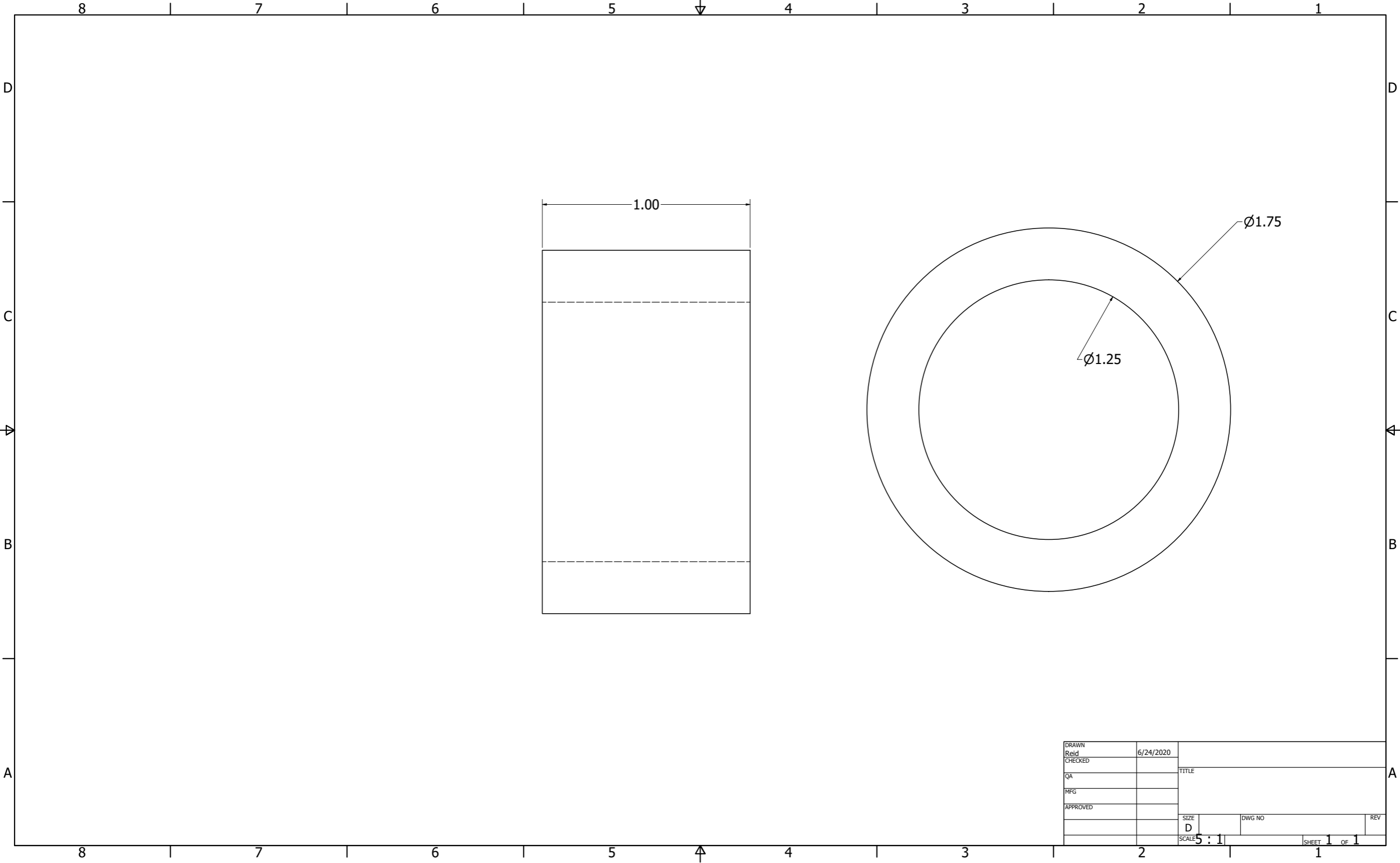

| | | | | | |
|----------|------|-----------|-------|--------|--------------|
| DRAWN | Reid | 6/24/2020 | | | |
| CHECKED | | | TITLE | | |
| QA | | | | | |
| MFG | | | | | |
| APPROVED | | | | | |
| | | | SIZE | DWG NO | REV |
| | | | D | | |
| | | | SCALE | 5 : 1 | SHEET 1 OF 1 |

Roller Expanded View

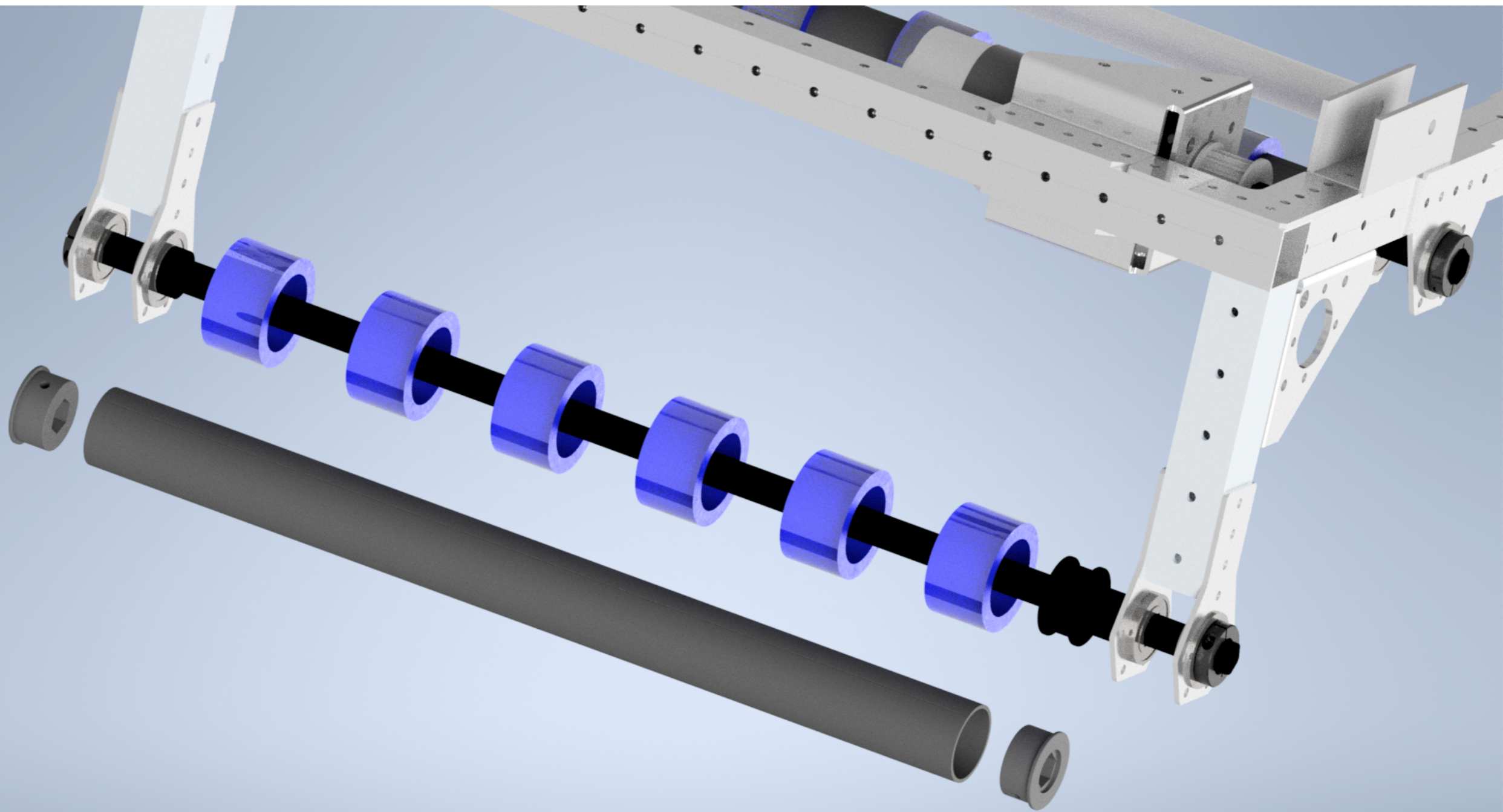

What it should look like

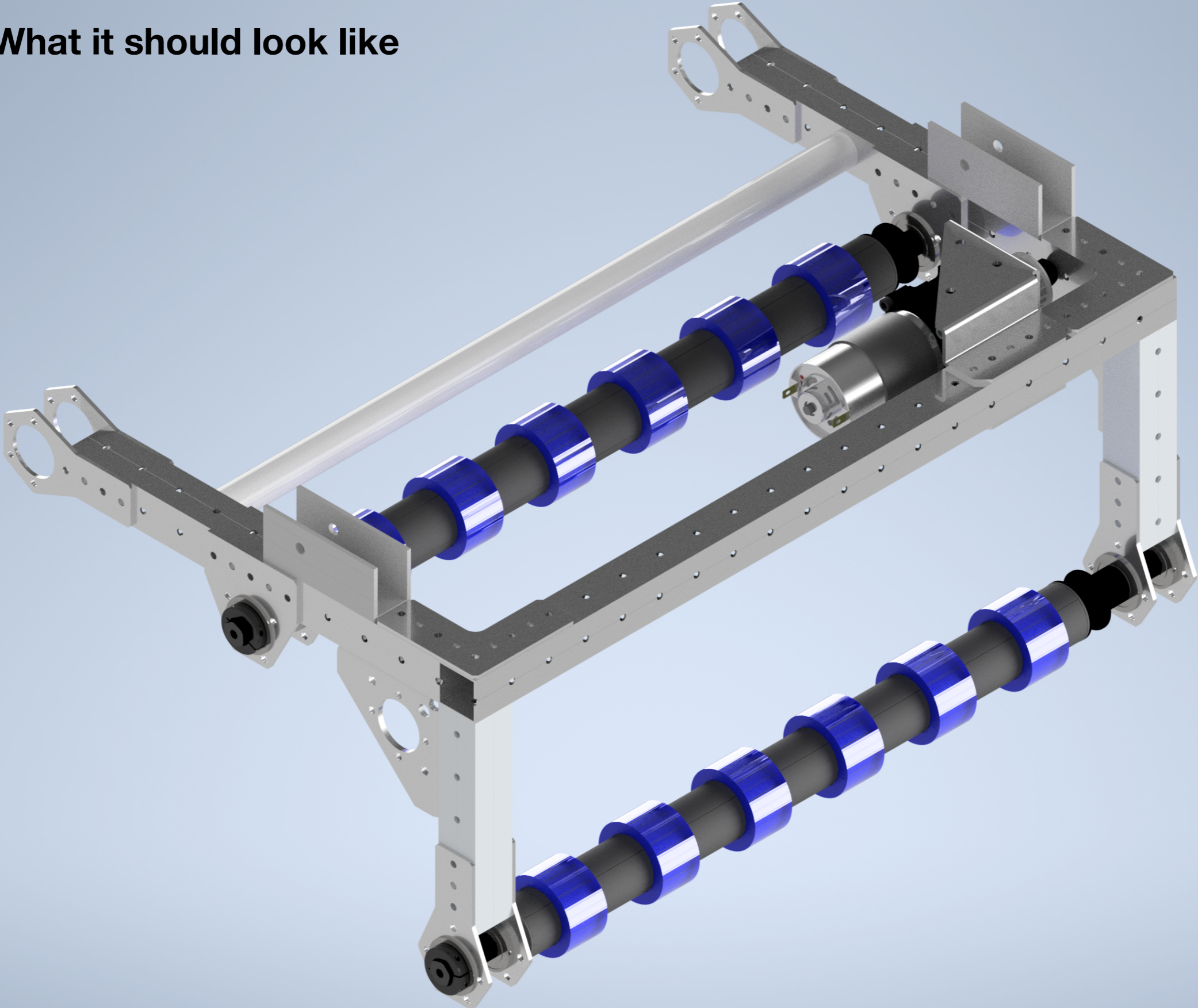

Bottom View

